

# XCell<sup>®</sup> LS Controllers

## User Guide

For integration with DeltaV<sup>™</sup> Systems

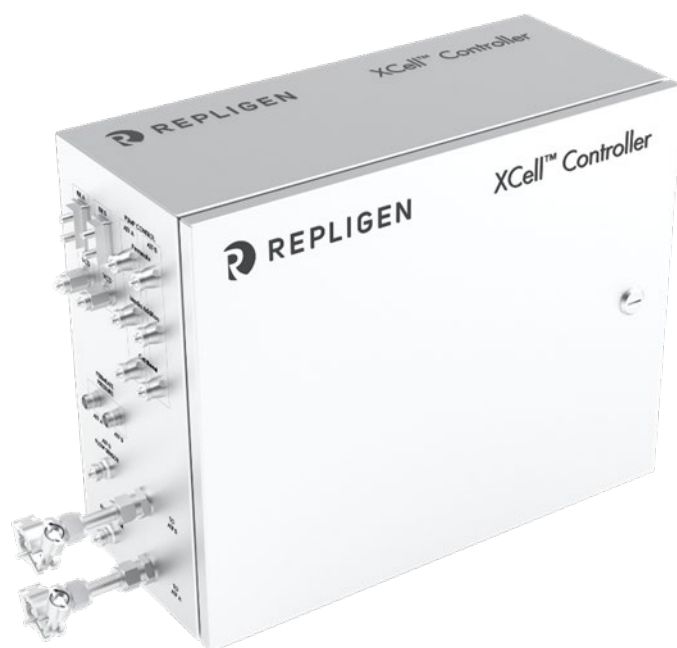

The information contained in this document is subject to change without notice.

With respect to documentation accompanying product, Repligen makes no warranty, express or implied. Any and all warranties related to the documentation accompanying product are expressly disclaimed. Customer shall refer to the terms and conditions of sale governing the transaction for any and all warranties for the Product.

Repligen Corporation shall not be liable for errors contained herein or for incidental or consequential damages in connection with the furnishing, performance, or use of this material.

No part of this document may be photocopied, reproduced, or translated to another language without the prior written consent of Repligen Corporation.

Products are not intended for diagnostic or therapeutic use or for use in vivo with humans or animals.

For further information, please contact Repligen Corporation at [www.repligen.com](http://www.repligen.com).

©2023 Repligen Corporation. All rights reserved. The trademarks mentioned herein are the property of Repligen Corporation and/or its affiliate(s) or their respective owners.

#### **Customer Support**

[customerserviceUS@repligen.com](mailto:customerserviceUS@repligen.com)

+1-800-622-2259 (Option 1)

#### **Repligen Corporation**

41 Seyon Street

Building 1 Suite 100

Waltham, Massachusetts 02453

[www.repligen.com](http://www.repligen.com)

## Contents

<b>1.</b>	<b>Introduction</b>	<b>5</b>
<b>2.</b>	<b>Controller Overview</b>	<b>5</b>
<b>3.</b>	<b>Controller Hardware</b>	<b>5</b>
<b>4.</b>	<b>Protocols</b>	<b>6</b>
<b>5.</b>	<b>XCell ATF® Device PLC tag mapping</b>	<b>6</b>
5.1	PLC data arrays	6
5.1.1	Ethernet I/P	6
5.1.2	Modbus TCP	6
5.2	Heartbeat	6
<b>6.</b>	<b>DeltaV™ System communication</b>	<b>7</b>
6.1	DeltaV™ System communication overview	7
6.2	DeltaV™ System communication cards and drivers	7
<b>7.</b>	<b>PLC configuration</b>	<b>8</b>
7.1	PLC IP address assignment	8
7.1.1	Changing the IP address	8
7.2	Physical connection	9
7.2.1	Creating the physical connection	9
<b>8.</b>	<b>DeltaV™ System configuration</b>	<b>9</b>
8.1	Software architecture	9
8.2	PK Controller	10
8.2.1	Ethernet I/P	10
8.3	VIM2 Card	11
8.3.1	IOD-4116 ODVA Ethernet I/P	11
8.3.2	Summary	13
8.4	Local HMI Control only	13
<b>9.</b>	<b>XCell ATF® Device Input / Output List</b>	<b>14</b>
9.1	Overview	14
9.2	Heartbeat	14
9.3	Configuration	14
9.4	Manual control of the process control valve	16
9.5	Starting in wetting mode	17
9.6	Start ATF	17
9.7	Running in dual mode	18
9.8	Alarms and advanced statuses	19
<b>10.</b>	<b>Recommendations for HMI development</b>	<b>19</b>
<b>11.</b>	<b>References</b>	<b>20</b>
11.1	EtherNet/IP	20
11.2	Modbus	20
11.3	DeltaV™ PK Controller	20
11.4	M-series Virtual I/O Module 2	20
11.5	S-series Virtual I/O Module 2	20
11.6	Ethernet I/O Card (EIOC)	20
11.7	FactoryTalk Linx	20
<b>12.</b>	<b>Index</b>	<b>21</b>

## List of tables

Table 1. Device drivers for the M-VIM2 and S-VIM2 cards.....	8
Table 2. Device drivers for the Ethernet I/O Card (EIOC) card (11.6).....	8
Table 3. Control Module Classes.....	9
Table 4. DeltaV™ Integration files - PK Controller Ethernet I/P.....	10
Table 5. VIM2 Ethernet I/P integration software package .....	11
Table 6. VIM2 I/O data set configurations.....	12
Table 7. Control modules.....	14
Table 8. Heartbeat tags.....	14
Table 9. Model availability tags .....	15
Table 10. Device size configuration tags.....	15
Table 11. Configuration error tags.....	15
Table 12. Permeate pressure monitoring activation and status tags.....	15
Table 13. XCell ATF® 10 Device flowmeter configuration tags.....	16
Table 14. Restart tags .....	16
Table 15. PCV manual control tags .....	16
Table 16. Wetting mode tags.....	17
Table 17. Individual XCell ATF® Device control tags .....	18
Table 18. Dual XCell ATF® Device Control tags .....	19

## List of figures

Figure 1. XCell® LS Controller enclosure and connectivity options .....	5
Figure 2. PLC program tag mapping .....	7
Figure 3. DeltaV™ System software architecture – PK Controller example .....	10
Figure 4. Local HMI Control Only.....	13

## Abbreviations

ATF	Alternating tangential flow
ATF-A	XCell ATF® Device A
ATF-B	XCell ATF® Device B
ETH 1,2	Ethernet ports
HMI	Human machine interface
INT	Integer
I/O	Input/output
I/P	Internet protocol
LPM	Liters per minute
OEM	Original equipment manufacturer
PLC	Programable logic controller
PCV	Process control valve
TCP	Transmission control protocol

## 1. Introduction

The purpose of this guide is to support the integration of the XCell® LS Controller into a DeltaV™ System. This guide is specific to the XCell® LS Controller architecture powered with a Rockwell PLC.

This integration guide provides steps and examples to help plan integration. Actual configuration needs and the order in which these steps are performed may vary. Please refer to XCell® LS Controllers User Guide for information on the XCell® LS Controller.

## 2. Controller Overview

The XCell® LS Controllers use an active process that continuously senses diaphragm pressure, permeate pressure, and the flow between the bioreactor and the XCell ATF® Device. Process parameters are adjusted in real-time to maintain the desired volume exchange and continuous perfusion. This system enables the XCell ATF® Technology to provide consistent performance across a wide range of process fluids with differing viscosities, concentrations, and temperatures.

## 3. Controller Hardware

The XCell® LS Controllers consist of a stainless-steel enclosure to house the PLC, Process Control Valve (PCV), and other necessary electrical components. The PLC is a CompactLogix L19ER from Allen-Bradley. The PCV is an Enfield SCEC-K-17000. The controller hardware supports connectivity to a variety of external control systems.

**Figure 1. XCell® LS Controller enclosure and connectivity options**

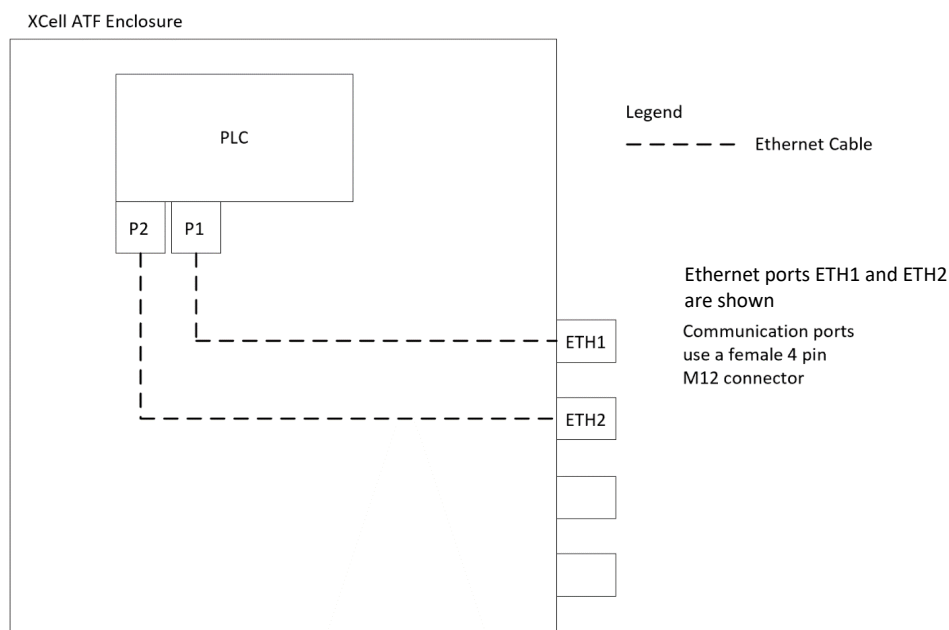

## 4. Protocols

Ethernet I/P is an industrial network protocol that adapts the Common Industrial Protocol to Standard Ethernet ([11.1](#)). It is widely used within the world of industrial automation. Within it are further selections, such as implicit vs. explicit messaging that define the nature of the communication between two devices.

Modbus TCP is a data communications protocol, originally published by Modicon, for use with its PLC ([11.2](#)). It uses the master/slave convention and includes defined object types to read/write addresses.

There are pros and cons to using each protocol. Repligen has tested both with the XCell® LS Controllers, providing sufficient communication for control.

## 5. XCell ATF® Device PLC tag mapping

The PLC control logic drives the core XCell ATF® Device operations. Communication occurs over Ethernet I/P and Modbus TCP protocols to enable supervisory control of the XCell ATF® Device into external DeltaV™ Systems. ETH1 and ETH2 ports provide an ethernet connection to the PLC.

Either of the two available protocols can be used to control the XCell ATF® Device process, however only one of them can be in control at any given time. The PLC code contains separate data arrays for each protocol and uses a heartbeat solution to pick the active one ([Section 5.2](#)).

### 5.1 PLC data arrays

The PLC code contains two sets of data arrays that can be connected to external DeltaV™ Systems to provide remote control: one to support Ethernet I/P communication and one for Modbus TCP. The information being exchanged is the same for both; communication simply occurs differently to serve the requirements of each protocol.

#### 5.1.1 Ethernet I/P

The PLC code makes the local N8 and N11 data arrays available for connection. N8 is an array of forty INTs that receives the control commands from the DeltaV™ System. N11 is an array of eighty-eight INTs that send status information back to the DeltaV™ System. The PLC code maps these two data arrays to its internal process tags. These integer file type mappings need to be configured in the DeltaV™ System and the resultant data arrays are pulled into the control modules, which arrange and describe the tags by type.

#### 5.1.2 Modbus TCP

The PLC code has one data array that supports all Modbus TCP communication. MBTU\_MB\_4xx is an array of 480 INTs that include both the control and status information exchanged with DeltaV™. This is an array of holding registers. The DeltaV™ System is configured with the necessary addressing to connect to the MBTU\_MB\_4xx data array and take control using Modbus TCP.

### 5.2 Heartbeat

The PLC code uses a heartbeat solution to choose the controlling protocol. It does so by monitoring the heartbeat tag with each data array. When one of the heartbeat tags becomes dynamic by toggling between 0 and 1, the PLC gives remote control to the associated protocol and maintains it until the heartbeat is lost. For example, when Ethernet I/P is being used, the I/O data array in the DeltaV™ System will connect to the Ethernet I/P data array in the PLC code as shown in [Figure 2](#).

Figure 2. PLC program tag mapping

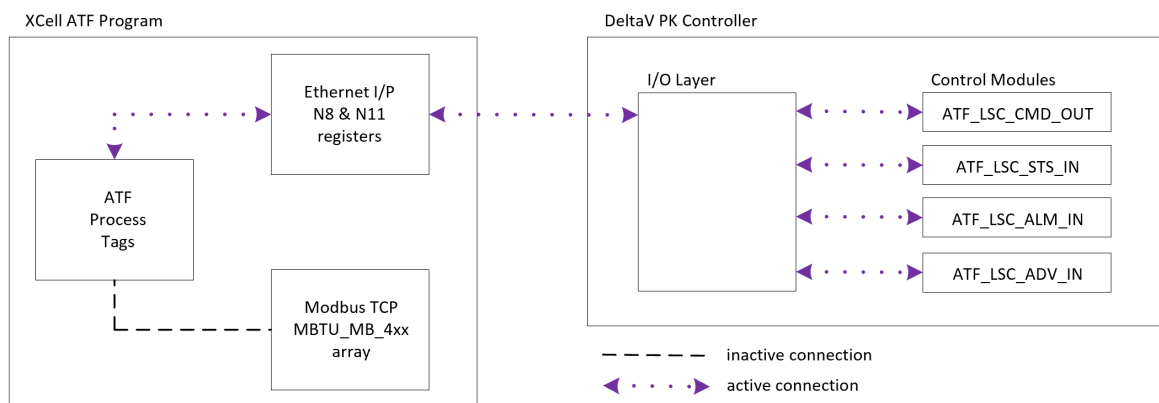

Because Ethernet I/P is the controlling protocol, the Ethernet I/P data array is mapped to the XCell® LS Controller process tags. This means that any changes to the Ethernet I/P data array are directly applied to the XCell ATF® System process tags. This mapping provides a synchronous connection between the I/O in the DeltaV™ System and the Ethernet I/P data array in the PLC and is the foundation for how the PLC code can be controlled remotely. If a tag changes in the PLC, the matching tag will update in the DeltaV™ System. If a start bit is set from DeltaV™, the PLC will read this change and use it to start the XCell ATF® Device process.

The active protocol and associated DeltaV™ System communication driver will define the nature of the communication. There are some minor differences in behavior between the two protocols and within each one depending on the selected DeltaV™ System driver. The XCell ATF® System PLC code was designed to support both protocols to provide integration flexibility.

## 6. DeltaV™ System communication

The DeltaV™ Distributed Control System (DCS) provides process control networks and a variety of deployment options. This guide focuses on Ethernet I/P and Modbus TCP, which are relevant to the XCell® LS Controllers.

### 6.1 DeltaV™ System communication overview

The DeltaV™ System platform includes several options for connecting over Ethernet I/P and Modbus TCP. With the traditional M and S series Controllers, the VIM2 and the EIOC cards provide connections. These are installed in the DeltaV™ System rack adjacent to the controller. Another option from Emerson is the PK Controller which is a standalone option for skid control. The ethernet cable is plugged in directly and no additional communication card is necessary.

### 6.2 DeltaV™ System communication cards and drivers

- M-series Virtual I/O Module 2 (M-VIM2) ([11.4](#))
- S-series Virtual I/O Module 2 (S-VIM2) ([11.5](#))
- Ethernet I/O Card (EIOC)
- PK Controller

Coupled with each hardware card is a device driver that defines the nature of the communication. The XCell ATF® Device process can be controlled by any of the three cards using one of the approved device drivers.

**Note:** For those drivers listed as supported, but without integration files, contact Repligen for integration support.

**Table 1. Device drivers for the M-VIM2 and S-VIM2 cards**

Device driver	Description	Supported by Repligen?	Integration files provided?
IOD-4111	Modbus TCP/IP Master Driver	Yes	No
IOD-4112	Ethernet I/P Scanner Driver	Yes	No
IOD-4115	FMC722 Ethernet Protocol Driver	No	No
IOD-4116	ODVA Ethernet I/P Protocol Driver	Yes	Yes
IOD-4117	Profinet Protocol Driver	No	No

**Table 2. Device drivers for the Ethernet I/O Card (EIOC) card (11.6)**

Device driver	Description	Supported by Repligen?	Integration files provided?
VE4103	Modbus TCP Interface	Yes	No
VE4104	Ethernet I/P Control Tag Integration for Ethernet-connected I/O (EIOC)	Yes	No
VE4105	Ethernet I/P Interface for Ethernet connected I/O (EIOC)	Yes	No
VE4106	OPC-UA client for Ethernet connected I/O (EIOC)	No	No
VE4107	IEC 61850 MMS Interface for Ethernet connected I/O (EIOC)	No	No
VE4109Sxxx	Ethernet connected I/O (EIOC and PK): nn Physical Devices	No	No

The PK Controller system does not require purchasing separate communication drivers. It comes with native drivers to support Ethernet I/P and Modbus TCP. Both options are supported by the XCell ATF® Device PLC. Currently Repligen provides the integration files for the Ethernet I/P integration ([Section 9.2](#)).

## 7. PLC configuration

### 7.1 PLC IP address assignment

With any of the available integration options, it is necessary to fit the XCell ATF® Device PLC into the existing DeltaV™ System network. This includes assigning it a new static IP address, following site IT guidance.

The PLC is a CompactLogix L19ER which is part of the Logix family from Allen-Bradley. It has a default IP address of 192.168.1.101.

#### 7.1.1 Changing the IP address

1. Download and install FactoryTalk Linx software ([11.7](#)) onto a laptop.
2. Change the IP address of the laptop to 192.168.1.200 to match the PLC subnet.
3. Use an ethernet cable to connect the laptop to ETH1 or ETH2 on the XCell ATF® Device enclosure.
4. Power up the XCell ATF® enclosure.
5. Open FactoryTalk Linx and connect to the PLC.
6. Set the new PLC IP address.



The laptop will lose communication after the IP address is changed. This completes the configuration on the PLC side. All remaining configurations will happen within the DeltaV™ System and is dependent on the DeltaV™ System hardware, selected protocol, and communication driver.

## 7.2 Physical connection

The integration of the XCell ATF® System with DeltaV™ System requires a physical ethernet connection.

### 7.2.1 Creating the physical connection

1. Connect one end of an ethernet cable to ETH1 or ETH2 on the XCell® LS Controller enclosure and the other end to a port with DeltaV™ System connectivity. The XCell™ PLC should now be pingable from within the DeltaV™ System subnet.
2. Confirm a successful ping before proceeding to the next section.

## 8. DeltaV™ System configuration

The DeltaV™ System must be configured to communicate correctly with the XCell ATF® System PLC. The configuration is dependent on the existing DeltaV™ System communication hardware and software.

### 8.1 Software architecture

Repligen has standardized on a set of 4 control modules to aggregate and organize the I/O signals by their function. These control module classes are consistent across all the different integration solutions. While the classes are the same, the instantiated modules differ depending on which protocol has been selected. Each protocol will require a different I/O configuration to connect to the data arrays within the XCell ATF® Device PLC. Repligen aims to facilitate integration by providing not just the classes but plant areas for each type of integration. This way, the I/O mapping is already complete, and the relevant files just need to be imported.

**Table 3. Control Module Classes**

Command	Description
ATF_LSC_CMD_OUT	Command Outputs
ATF_LSC_STS_IN	Status Feedback
ATF_LSC_ALM_IN	Alarms
ATF_LSC_ADV_IN	Advanced

**Figure 3. DeltaV™ System software architecture – PK Controller example**

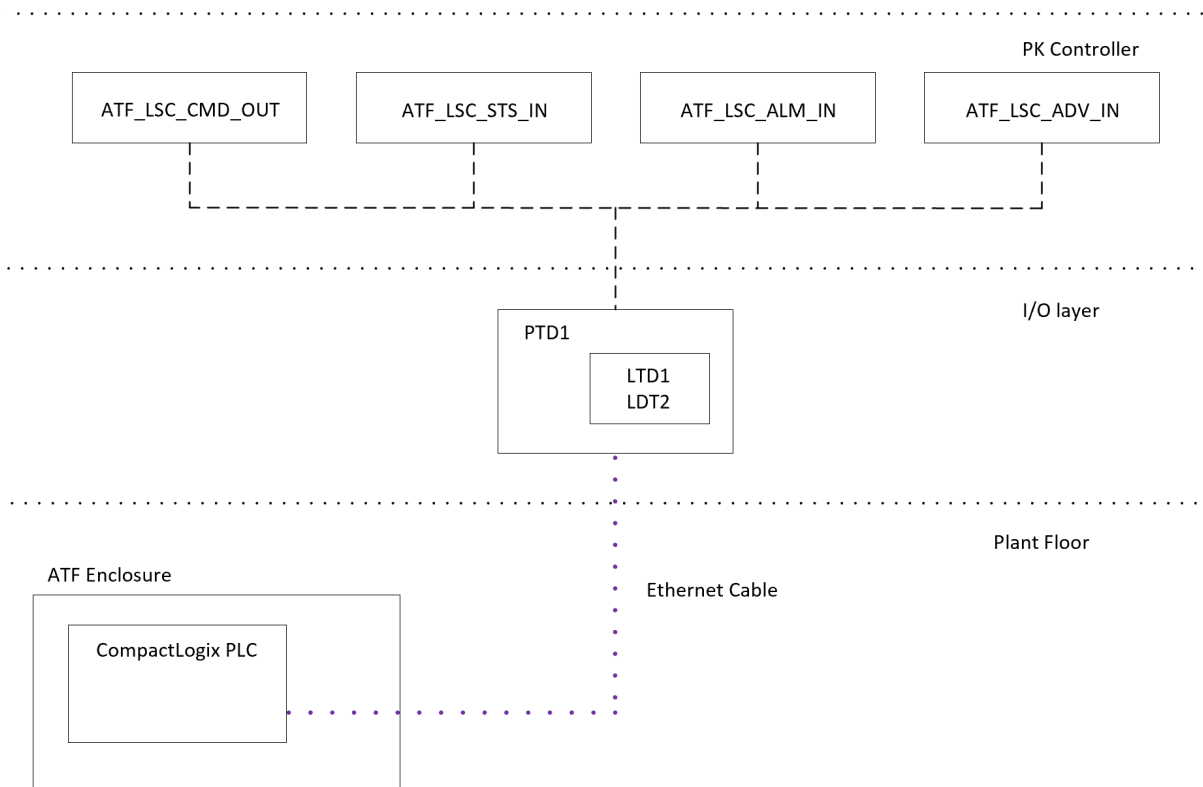

Repligen aims to provide all necessary DeltaV™ System software up to the control module layer. As of this time Repligen does not provide higher level code such as Equipment Modules or any HMI screens / faceplates.

### 8.2 PK Controller

The PK Controller is an increasingly popular option that is powerful enough to be standalone, but also flexible enough to integrate into larger DeltaV™ control systems. Unlike the M & S Series Controllers, the PK comes with built-in ethernet ports that can be configured for Ethernet I/P or Modbus TCP. The ports are configurable with IP address and port numbers which makes it easy to match the subnet of the PLC IP address. For this integration, the XCell ATF® Device can be connected directly to the ethernet port on the PK Controller.

#### 8.2.1 Ethernet I/P

Repligen has standardized on UCMCM with Logix Tags communication to connect the PK Controller to the N8 and N11 PLC registers. Repligen provides all necessary software to complete the configuration steps.

**Table 4. DeltaV™ Integration files - PK Controller Ethernet I/P**

File name	Description
P01.fhx	Ethernet I/O Port Configuration
XCELL_LM_PK.fhx	plant area with a unit module containing 4 linked control modules
ATF_LSC_ADV_IN	ATF LSC Advanced Statuses control module class
ATF_LSC_ALM_IN	ATF LSC Alarms control module class
ATF_LSC_CMD_OUT	ATF LSC Commands control module class
ATF_LSC_STS_IN	ATF LSC Statuses control module class

The P01.fhx file contains the I/O configuration information to connect to the ATF PLC. It contains the Ethernet I/P Physical Device which contains 2 Ethernet I/P Logical Devices: LDT1 and LDT2. LDT1 is the input data array that connects to the N11 array in the CompactLogix and LDT2 is the output data array that connects to the N8 array.

XCELL\_LM\_PK.fhx is a plant area with a unit module containing instances of the 4 control module classes linked to the I/O defined in P01.fhx. The 4 control module classes are also included. Importing these files provides a quick and complete integration. The files are available upon request from the Repligen R&D Automation Team.

## 8.3 VIM2 Card

### 8.3.1 IOD-4116 ODVA Ethernet I/P

This section applies to DeltaV™ Systems that are running the IOD-4116 communication driver on a VIM2 card.

#### 8.3.1.1 Overview

Explicit connected class 3 messaging is used to connect DeltaV™ System to the PLC N8 and N11 data arrays.

There are three layers of DeltaV™ System configuration involved in this integration:

- Configuration of the VIM2 card to map to the N8 and N11 PLC registers
- Configuration of the DeltaV™ System I/O layer to match the VIM2 arrays
- Configuration of the DeltaV™ System modules that connect to the I/O layer

Repligen provides all necessary software to complete the configuration steps.

**Table 5. VIM2 Ethernet I/P integration software package**

File Name	Description
ATF_LSC_4116_VIM.vio	VIMNet Explorer file
ATF_LSC_4116_DVIO.fhx	DeltaV™ System I/O configuration
ATF_LSC_ADV_IN	XCell® LS ControllerLSC Advanced Statuses control module class
ATF_LSC_ALM_IN	XCell® LS ControllerLSC Alarms control module class
ATF_LSC_CMD_OUT	XCell® LS ControllerLSC Commands control module class
ATF_LSC_STS_IN	XCell® LS ControllerLSC Statuses control module class
XCELL_LM_4116	plant area with unit module and 4 linked landing modules

#### 8.3.1.2 DeltaV™ I/O - VIMNet pairing

The VIM2 card is linked to the C57, C58, C59, and C60 cards in the I/O layer of the controller that it is serving. During internal testing, Repligen created DEV01 within Port 01 of C57 to communicate with the XCell ATF® Controller. This device location is matched within the VIMNet Explorer file. It is not important which of the 4 cards and nested ports are utilized, but it is necessary to ensure a match between the DeltaV™ I/O configuration and the VIMNet configuration. It is also important to match the Device Address in each location.

Depending on the existing plant VIM2 I/O, the location of the XCell ATF® System may need to move from the default of C57 Port 01. The ATF\_LSC\_4116\_DVIO.fhx software is provided as an example of a working configuration and can either be imported directly or tweaked to better fit existing plant I/O configurations. It will only import C57 into the DeltaV™ I/O layer.

There are two configured data sets within DEV01 of the import file:

- DS01 connects to PLC tag array N11 to receive the XCell® LS Controller status information.
- DS02 connects to PLC tag array N8 to publish the XCell® LS Controller commands.

**Table 6. VIM2 I/O data set configurations**

Location	DS01	DS02
<b>General Tab</b>		
Data direction	input	output
output mode	0	0, no readback
<b>DeltaV™ Tab</b>		
DeltaV™ data type	16-bit int w/status	16-bit int w/status
<b>PLC Tab</b>		
Device data type	0	0
Data start address	0	0
Number of values	88	40
<b>Special Data Tab</b>		
Special data 1	7	7
Special data 2	11	8
Special data 3	0	0
Special data 4	0	0
Special data 5	0	0

#### Configure the VIMNet:

The VIMNet configuration includes two connection definitions within the Serial Card Ethernet IP Definition Library.

- C3DF1\_N:11/0-0 defines the VIM2 connection to N11 within the PLC
  - C3DF1\_N:8/0-0 defines the VIM2 connection to N8 within the PLC
1. Open the ATF\_LSC\_4116\_VIM.vio file to view these connection definitions and see how they are deployed within the I/O Net layer.
  2. Within DEV01, change the IP address to match the ATF PLC address set in [Section 7.1](#).
  3. After the DeltaV™ System I/O and VIMNet configurations have been finalized, download the DeltaV™ System I/O.
  4. Upload the VIMNet configuration to the VIM2 card.
  5. This should provide the necessary communication between DeltaV™ System and the PLC. Run DeltaV™ System diagnostics to view the registers in the data sets.
  6. Confirm a healthy and active connection between DeltaV™ System and the ATF PLC before proceeding.

### 8.3.2 Summary

Once the I/O and control modules are in place, and the controller downloads are complete, the XCell® LS Controller is ready to be controlled remotely from DeltaV™ System. [Section 10](#) describes how the available tags within DeltaV™ can be used to achieve the desired process control.

### 8.4 Local HMI Control only

The XCell ATF® Device can also be controlled only by using the local HMI.

**Figure 4. Local HMI Control Only**

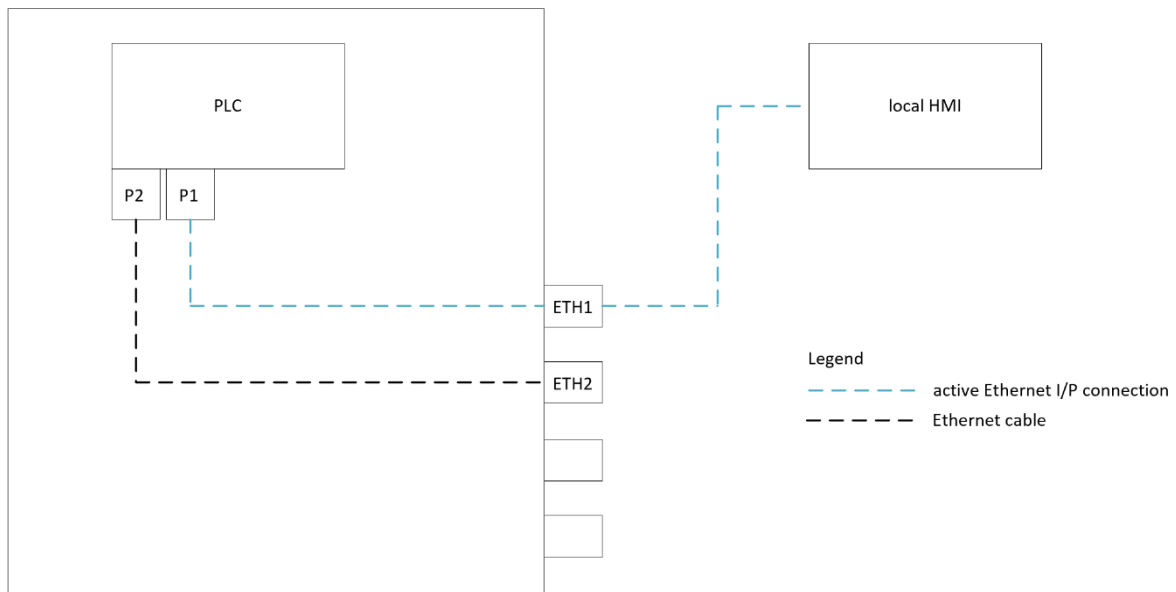

## 9. XCell ATF® Device Input / Output List

### 9.1 Overview

The XCell ATF® Device I/O list is a consolidation of all input / output signals hosted in the control module layer. It contains 1 tab for each control module class. The filename is *XCell ATF® Device LSC IO List.xlsx*.

This section illustrates a typical setup from initial configuration through running the more advanced features of the technology. The steps are provided as a guideline. The exact order and number of steps may vary, depending on your individual configuration. Throughout this section, the relevant I/O tags will be highlighted and explained.

It is recommended that you read and reference the XCell® LS Controllers User Guide for details regarding the correct setup, configuration, and use of the system.

**Table 7. Control modules**

Command	Description
ATF_LSC_CMD_OUT	Command Outputs
ATF_LSC_STS_IN	Status Feedback
ATF_LSC_ALM_IN	Alarms
ATF_LSC_ADV_IN	Advanced

### 9.2 Heartbeat

Before the PLC code will respond to any commands from Ethernet I/P or Modbus TCP, it is necessary to actively toggle the heartbeat command tag to claim the master designation. This designation can be confirmed by monitoring the heartbeat status tag. There is also a heartbeat signal coming from the PLC code than can be monitored as a confirmation of healthy Ethernet I/P communication even when the master designation has not been assigned.

**Table 8. Heartbeat tags**

Tag name	Tab
SCADA_HB	ATF_LSC_CMD_OUT
MSTR_ETH	ATF_LSC_STS_IN
MSTR_MB	ATF_LSC_STS_IN
XCELL_HB	ATF_LSC_STS_IN

The ATF\_LSC\_CMD\_OUT control module is responsible for toggling the SCADA\_HB command. Once the designation is assigned, MSTR\_ABDF1 or MSTR\_MB will transition from 0 to 1, depending on which protocol is sending the heartbeat. Within the PLC, this designation will map the active protocol tags to the XCell ATF® Device process tags.

### 9.3 Configuration

The LSC ATF PLC code is written to support a variety of physical product configurations including XCell ATF® 4, 6, and 10 Devices, with the presence/absence of a permeate pressure monitor (P3), etc.

1. Verify the three XCell ATF® Device sizes are available by confirming a 1 value in model availability tags. It is important for the XCell ATF® Device size to be listed as available within the program.

**Table 9. Model availability tags**

Tag name	tab
MODEL_ATF4	ATF_LSC_STS_IN
MODEL_ATF6	ATF_LSC_STS_IN
MODEL_ATF10	ATF_LSC_STS_IN

2. Set the XCell ATF® Device A and B sizes in the program using the configuration tags to match the XCell ATF® Devices connected to the XCell ATF® Device enclosure and confirm the selections by monitoring the status tags.

**Table 10. Device size configuration tags**

Tag name	Tab
FA_SIZE	ATF_LSC_CMD_OUT
FB_SIZE	ATF_LSC_CMD_OUT
FA_ACTIVE_SIZE	ATF_LSC_STS_IN
FB_ACTIVE_SIZE	ATF_LSC_STS_IN

There are two tags to communicate configuration errors back from the PLC.

**Table 11. Configuration error tags**

Tag name	Tab
CFG_LOCKED_ERR	ATF_LSC_ALM_IN
CFG_RANGE_ERR	ATF_LSC_ALM_IN

3. If the XCell ATF® Device setup is using the permeate pressure monitoring option, activate this in the program and confirm the status change using the following tags.

**Table 12. Permeate pressure monitoring activation and status tags**

Tag name	Tab
MODEL_TMP	ATF_LSC_STS_IN
FA_P3_ENABLE	ATF_LSC_CMD_OUT
FB_P3_ENABLE	ATF_LSC_CMD_OUT
FA_P3_ENABLED	ATF_LSC_STS_IN
FB_P3_ENABLED	ATF_LSC_STS_IN

4. Configure the total flow calculation method. Set the BOOLS to reflect the design of the product configuration.

The XCell ATF® 10 Device has a flow range from 20 - 80 LPM. The design includes two tubes running between the device and the bioreactor to accommodate this flow. The PLC code includes an option to use one flowmeter on each tube and add the signals to calculate total flow, or to only use one flowmeter and double the signal to calculate total flow. The latter option assumes flow through each tube is equal. This selection is made when ordering the product. This option is configured within the program using tags ([Table 12](#)). These are only applicable for XCell ATF® 10 Devices and can be ignored for XCell ATF® 4 and 6 Devices.

**Table 13. XCell ATF® 10 Device flowmeter configuration tags**

Tag name	Tab
ATF10_A2B_1FT	ATF_LSC_CMD_OUT
ATF10_A2B_2FT	ATF_LSC_CMD_OUT
ATF10_A2B_1FT_EN	ATF_LSC_STS_IN
ATF10_A2B_2FT_EN	ATF_LSC_STS_IN

- Set restart options and confirm the status.

The PLC code supports the option to automatically restart the XCell ATF® Devices after power returns from an unanticipated power loss. Set the desired behavior and confirm the status using tags ([Table 13](#)).

**Table 14. Restart tags**

Tag name	Tab
RESTART_ENABLE	ATF_LSC_CMD_OUT
RESTART_ENABLED	ATF_LSC_STS_IN

#### 9.4 Manual control of the process control valve

The Process Control Valve (PCV) is responsible for controlling the pressure under the diaphragm (P2) in the XCell® ATF Device housing. It receives the utility inputs for pressure and vacuum and controls to a pressure SP signal sent from the PLC. It has two outputs to cover XCell ATF® Devices A and B. This section details how it can be manually controlled.

**Table 15. PCV manual control tags**

Tag name	Tab
PCVA_ON_CMD	ATF_LSC_CMD_OUT
PCVA_SP	ATF_LSC_CMD_OUT
PCVA_CV	ATF_LSC_STS_IN
FA_P2_PV	ATF_LSC_STS_IN
PCVA_READY	ATF_LSC_STS_IN
PCVB_ON_CMD	ATF_LSC_CMD_OUT
PCVB_SP	ATF_LSC_CMD_OUT
PCVB_CV	ATF_LSC_STS_IN
FB_P2_PV	ATF_LSC_STS_IN
PCVB_READY	ATF_LSC_STS_IN



The PCVX\_READY signals indicate the XCell ATF® Device PCVs are ready to be manually controlled.

The PCVX\_ON\_CMD commands will apply power to the PCV and cause it to control P2 pressure to the values in the PCVX\_SP tags. The PCVX\_SP tags accept between -95 and 100% which correlate to full vacuum and full pressure. The PCVX\_CV tags are a reflection from the PCV of the PCVX\_SP back to the PLC. The FX\_P2\_PV tags represent the actual sensed pressure.

For both XCell ATF® Devices A and B, experiment with setting various percent values for the PCVX\_SP and activating the PCV by setting the PCVX\_ON\_CMD to 1. Observe how the PCVX\_CV and FX\_P2\_PV signals change in response to the changing setpoints. For single-use products, it is possible and helpful to watch the diaphragm within the device housing as it moves in response to the changing setpoints.

Set the PCVX\_ON\_CMD commands back to 0 to remove power from the PCV.

### 9.5 Starting in wetting mode

Wetting mode is a simplified control regime that does not adjust the process parameters in response to the observed flowrate. It simply runs the process with defined pressure and exhaust setpoints. This mode is commonly used at the beginning of the run to wet the XCell ATF® Device with media before the cells are introduced into the bioreactor.

**Table 16. Wetting mode tags**

Tag name	Tab
FA_WET_EXHST_SP	ATF_LSC_CMD_OUT
FA_FILTER_WET	ATF_LSC_CMD_OUT
FA_WET_PRESS_SP	ATF_LSC_CMD_OUT
FB_WET_EXHST_SP	ATF_LSC_CMD_OUT
FB_FILTER_WET	ATF_LSC_CMD_OUT
FB_WET_PRESS_SP	ATF_LSC_CMD_OUT

Repligen recommends that this procedure be conducted separately for XCell ATF® Devices A and B.

1. Use FX\_WET\_PRESS\_SP and FX\_WET\_EXHST\_SP to define the pressure and exhaust setpoints the ATF will cycle between as it runs in the wetting mode.
2. Choose two setpoints within the full range and activate wetting mode by setting FX\_FILTER\_WET to 1. FX\_FILTER\_WET is a sustained tag that needs to remain at 1 for wetting mode to operate.
3. Observe the P2 value over time as the process runs. Trending P2 will visualize the pressure curve over time which is the fundamental force that is driving the XCell ATF® Device process.
4. Return FX\_FILTER\_WET to 0 to stop the XCell ATF® Device.

### 9.6 Start ATF

This procedure starts normal operation of a single, independent XCell ATF® Device. The XCell ATF® Device will step through its initialization procedure before transitioning into running. The process is started with a flowrate SP and will adjust its process parameters over time to seek the desired performance. It also includes several operational modes that can be activated as needed by the operator. Consult the XCell® LS Controllers User Guide for descriptions of these modes and how they can be used to adjust to changing process conditions.

**Table 17. Individual XCell ATF® Device control tags**

Tag name	Tab
FA_FLOW	ATF_LSC_CMD_OUT
FA_PAUSE_CMD	ATF_LSC_CMD_OUT
FA_START_CMD	ATF_LSC_CMD_OUT
FA_STOP_CMD	ATF_LSC_CMD_OUT
FA_OPN_LOOP	ATF_LSC_CMD_OUT
FA_AVG_DIS	ATF_LSC_CMD_OUT
FA_RPD_RSP_EN	ATF_LSC_CMD_OUT
FA_HEADPRESS	ATF_LSC_CMD_OUT
FB_FLOW	ATF_LSC_CMD_OUT
FB_PAUSE_CMD	ATF_LSC_CMD_OUT
FB_START_CMD	ATF_LSC_CMD_OUT
FB_STOP_CMD	ATF_LSC_CMD_OUT
FB_OPN_LOOP	ATF_LSC_CMD_OUT
FB_AVG_DIS	ATF_LSC_CMD_OUT
FB_RPD_RSP_EN	ATF_LSC_CMD_OUT
FB_HEADPRESS	ATF_LSC_CMD_OUT

1. Use the FX\_HEADPRESS commands provide the initialization sequence with an estimated head pressure. This helps the ATF Process start with more useful process parameters.
2. For both XCell ATF® Devices A and B, input the desired flowrate into FX\_FLOW and set FX\_START\_CMD to 1 to start the ATF Process.
3. Reference the status tags in ATF\_LSC\_STS\_IN for an understanding of where the XCell ATF® Device is in its process. These tags include detail on the steps of the initialization process that occur when the ATF is first started.
4. Once the ATF is running, use the FX\_OPN\_LOOP tag to change it to open loop mode. Average Mode can be disabled using FX\_AVG\_DIS, and Rapid Response Mode can be enabled using FX\_RPD\_RSP\_EN.
5. The ATF can be paused using the FX\_PAUSE\_CMD tag and stopped using the FX\_STOP\_CMD tag.
6. Stop the ATF by setting the FX\_STOP\_CMD tag to 1.

FX\_START\_CMD, FX\_PAUSE\_CMD, and FX\_STOP\_CMD are all momentary tags in the PLC which means they are returned to 0 in DeltaV™ System after the action has been observed in the ATF Process. The reset is done automatically by the ATF\_LSC\_CMD\_OUT control module.

ATF\_LSC\_STS\_IN contains feedback tags that give insight into how the ATF Process is performing. P2 and F1 give instantaneous signals for diaphragm pressure and retentate flow rate. These signals are averaged in the PLC and included in the feedback tags as well as information on average percentage dwell and cycle counters.

### 9.7 Running in dual mode

This section discusses how to run XCell ATF® Devices A and B together in dual mode. The devices can be configured to run in phase, out of phase or independently. Running the XCell ATF® Devices out of phase is the most common approach as it minimizes the change in working volume in the bioreactor.

**Table 18. Dual XCell ATF® Device Control tags**

Tag name	Tab
DX_IN_PHASE_CMD	ATF_LSC_CMD_OUT
DX_OUT_PHASE_CMD	ATF_LSC_CMD_OUT
DUAL_ERR	ATF_LSC_ALM_IN
DX_IN_PHASE	ATF_LSC_STS_IN
DX_OUT_PHASE	ATF_LSC_STS_IN
MODEL_DUAL	ATF_LSC_STS_IN

ATF\_LSC\_CMD\_OUTUT lists all the necessary dual command and status tags. These can be used in accordance with the recommendations for the similar tags for single devices, except that they apply to running both XCell ATF® Devices simultaneously.

1. Using the Dual tags, assign the XCell ATF® Device size.
2. Set the devices to run in phase, out of phase, or in independent mode. Independent mode is achieved by setting both DX\_IN\_PHASE\_CMD and DX\_OUT\_PHASE\_CMD to 0.
3. Set a desired flowrate.
4. Start the XCell ATF® Devices together using DX\_START\_CMD. The XCell ATF Devices will run through their initialization phases and start run mode together.
5. Stop the XCell ATF® Devices by setting DX\_STOP\_CMD tag to 1.

DX\_START\_CMD, DX\_PAUSE\_CMD, and DX\_STOP\_CMD are all momentary tags in the PLC which means they need to be returned to 0 in DeltaV™ System after the action has been observed in the process.

### 9.8 Alarms and advanced statuses

ATF\_LSC\_ALM\_IN contains XCell ATF® System alarms. These alarms are calculated in the PLC code and can be used for troubleshooting. If desired, these alarms can be included into an alarm notification system within DeltaV™ System to alert operators of any operational issues. The ALARM\_RESET\_CMD tag in ATF\_LSC\_CMD\_OUT is used to reset the alarms by setting it to 1 and then returning it to 0.

ATF\_LSC\_ADV\_IN contains advanced status information that describes how the process is functioning. This includes details on the observed endpoints of the P2 curve, the quality of data exchange between the PLC and the flowmeters, the active mode, and event counters that track the events calculated within the XCell ATF® System algorithm. This information is read-only and not necessary for basic control of the process.

## 10. Recommendations for HMI development

HMI design is specific to the standards and preferences of the end-user DeltaV™ System. Repligen recommends using this integration guide as a starting point for the HMI development, with I/O list and the tag descriptions as the primary input for interface development.

In addition to this integration guide, The XCell® LS Controllers User Guide includes screenshots for the Repligen Wonderware-based local HMI.

## 11. References

11.1 [EtherNet/IP](#)

11.2 [Modbus](#)

11.3 [DeltaV™ PK Controller](#)

11.4 [M-series Virtual I/O Module 2](#)

11.5 [S-series Virtual I/O Module 2](#)

11.6 [Ethernet I/O Card \(EIOC\)](#)

11.7 [FactoryTalk Linx](#)

## 12. Index

Alarms .....	19	DeltaV communication .....	7, 9
Configuration .....	5, 8, 9, 10, 11, 12, 15, 16	Drivers.....	7, 8
Connectivity .....	5, 9	Protocols .....	6, 7
Controller hardware.....	5	Wetting mode.....	17