

Fully automate processes

with a suite of integrated hardware components

1/2" KrosFlo® Single-Use Tangential Flow Filtration (TFF) Systems integrate unique hardware to deliver significantly higher product yields and operational success through increased automation capabilities.

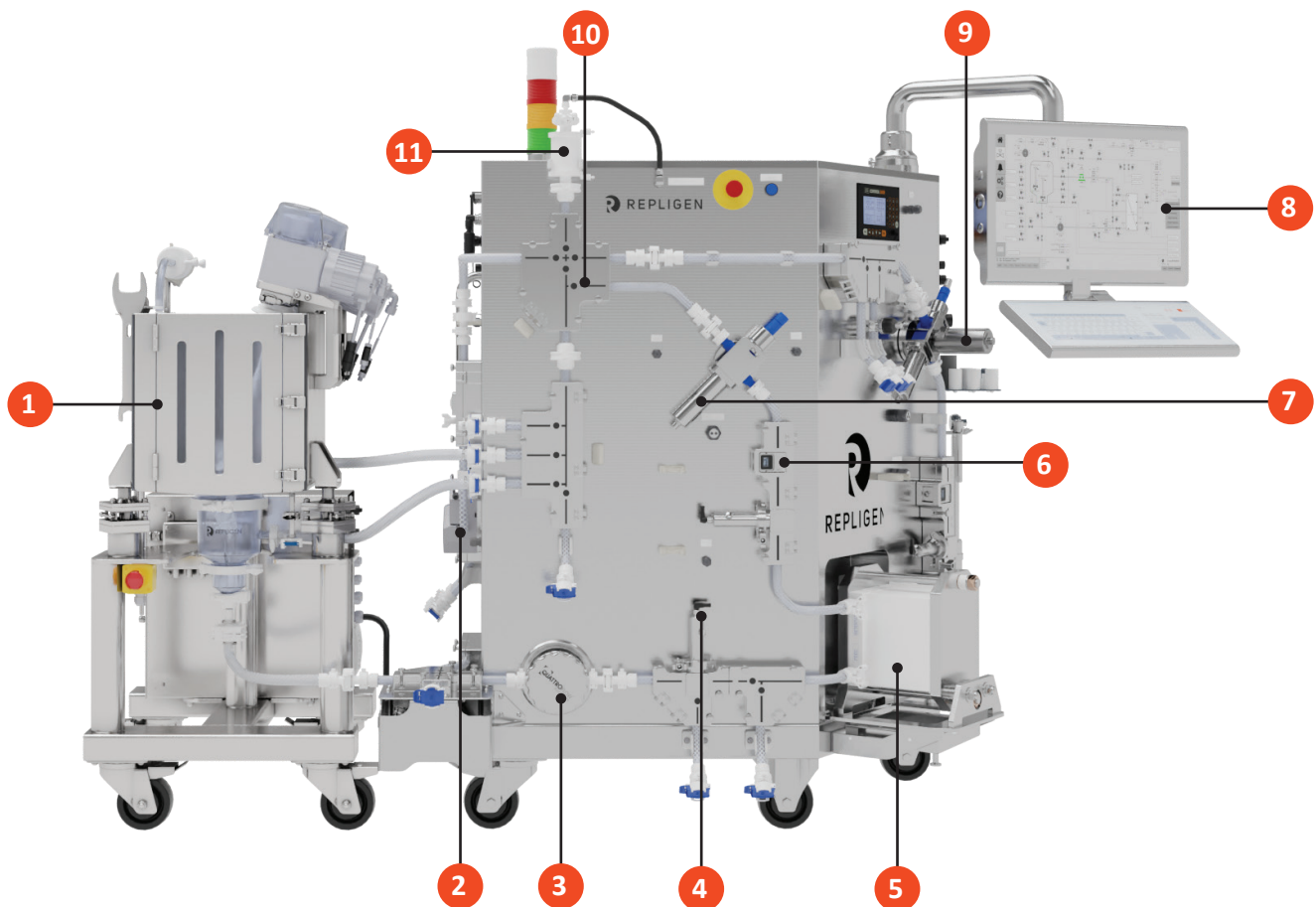

Components

- | | |
|---|--|
| 1. 50 L Tulip recirculation vessel | 7. Retentate Conductivity and pH Sensor (Optional) |
| 2. Peristaltic pump (addition) | 8. 21" Touch screen and keyboard |
| 3. Diaphragm pumps (feed and recirculation) | 9. Permeate Conductivity and Temperature Sensor (pH/UV optional) |
| 4. Pressure sensors (feed, retentate, and permeate) | 10. TMP Control Valve |
| 5. Cassette-holder | 11. Process air inlet (for integrity testing) |
| 6. Flow meters (retentate and permeate) | |



Deliver high recovery and operational simplicity

with engineered flow paths

ProConnex® Flow Paths integrate advanced fluid management technologies, including over-molded connections, pump heads, tubing, filters, and sensors in a single-use device. Flow paths easily attach to the system to simplify operation and increase process efficiency.

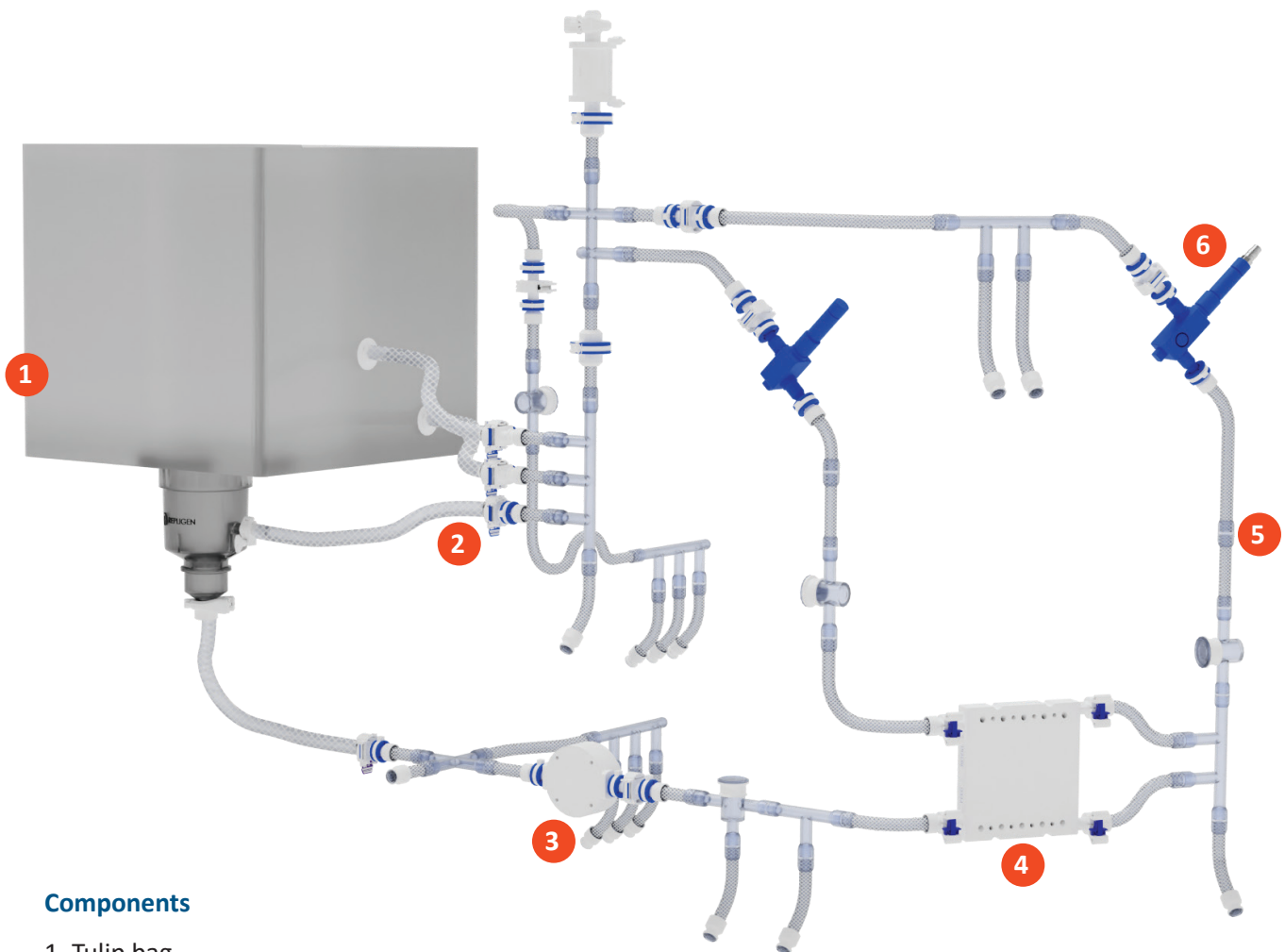

Components

1. Tulip bag
2. Recirculation loop inlet ports
3. Diaphragm pump head
4. Filter plate insert
5. Over-molded connections
6. Integrated sensors

Repligen 0011-0001

Signature features and advanced engineering

cGMP compliant, fully automated 1/2" Single-Use Tangential Flow Filtration (TFF) System, with low hold-up volume, small footprint, and outstanding performance.

Dimensions

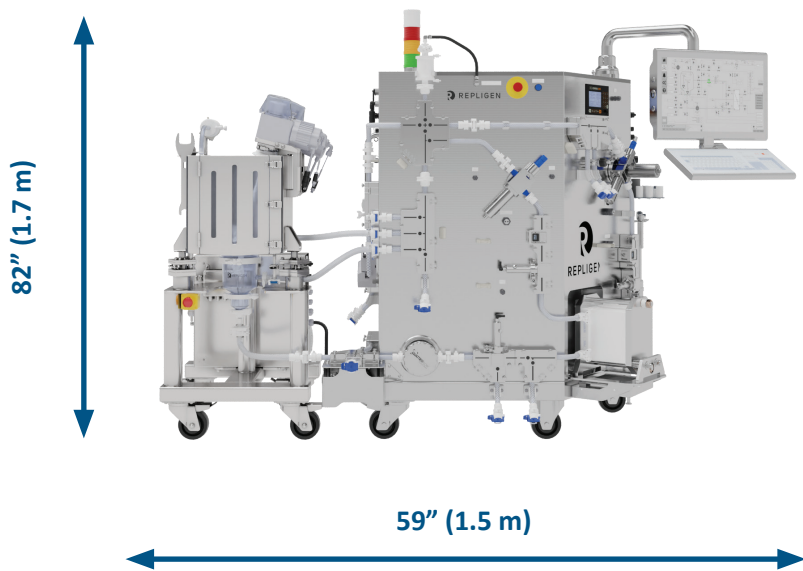

System process overview	
Membrane area	1 - 3 m ²
Addition flow rate	Maximum 7.5 LPM
Recirculation flow rate	0.2 - 15 LPM
Recirculating loop volume without filter cassettes	≤ 800 mL
Minimum working volume	1.5 L with 50 L tulip tank

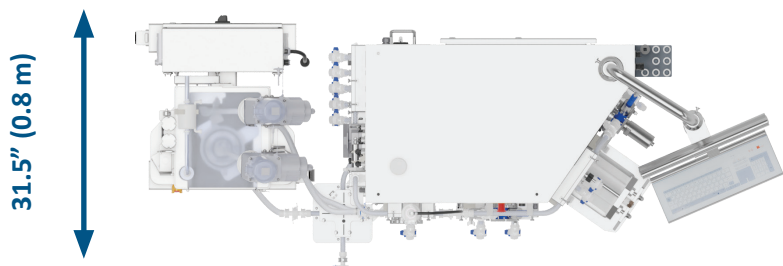

System mechanical overview	
System size	59" W x 31.5" D x 82" H
Power main	120 - 240 VAC (+/- 10%), 1 ph, 50/60 Hz, 15A
Power instruments	120-240 VAC (+/- 10%), 1 ph, 50/60 Hz, 15A
MoC	304 L SS #3A (System)



Dynamic control and response to changing fluid

levels for maximum product recovery

The single-use tulip tank recirculation vessel is designed to be used in combination with KrosFlo® Tangential Flow Filtration (TFF) Systems to carry out fed-batch, batch concentration, and diafiltration processes using a product recirculation bag, load cell and two top-mounted mixers. Multi-level inlets ensure superior recirculation performance.

Dimensions

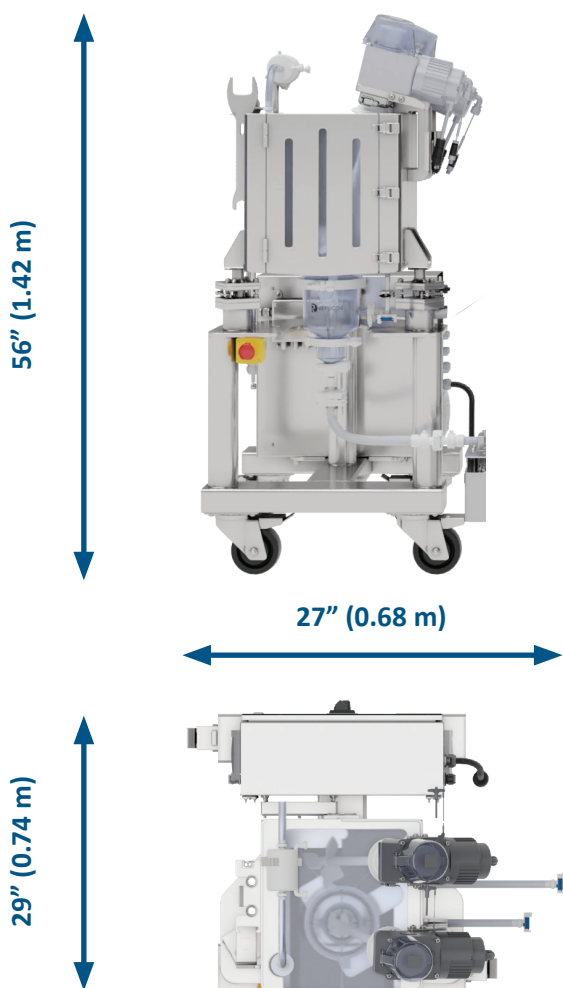

System overview	
Model	TULIP050
System size	27" W x 29" D x 56" H
Minimum and maximum working volume	1.5 L - 150 L
Sensors	
Multi-use sensors	Vessel weight (Load cell)
Agitation	
Mixing rate range	0 - 150 rpm

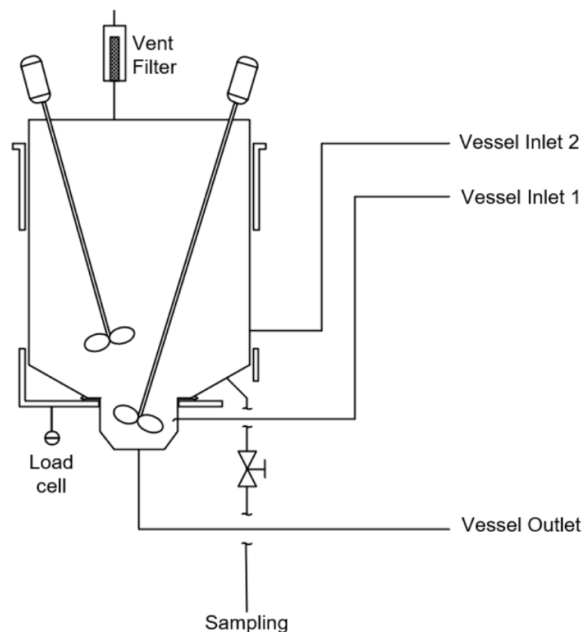

Expand filtration capabilities and automate more process sequences with additional valves

Single-use 1/2" Tangential Flow Filtration (TFF) System process flow diagram.

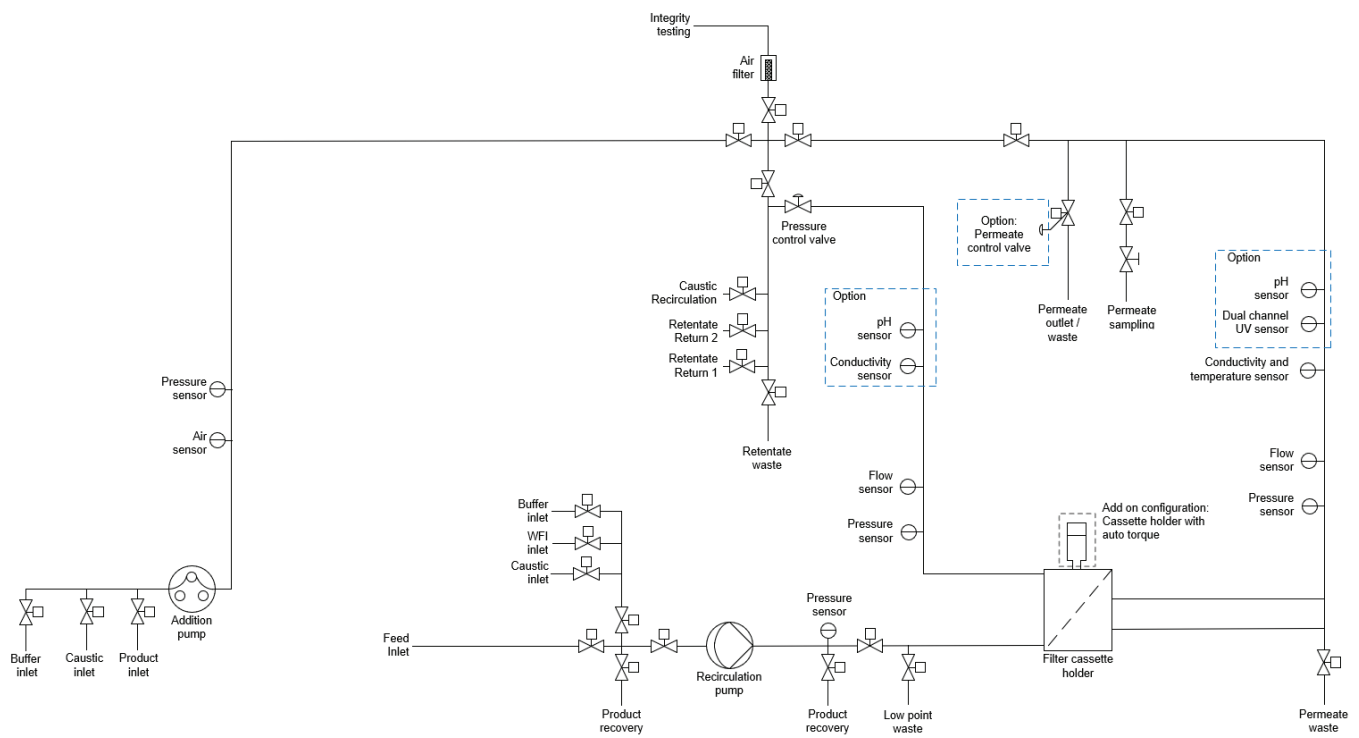

Revised 08/11/2017



Specifications

System specifications	
Membrane area	1 - 3m ²
Recirculation pump	Maximum 15 LPM Diaphragm
Addition pump	Maximum 7.5 LPM Peristaltic
Over pressure protection	Yes
Maximum flow-path pressure	4 bar
Recirculation loop volume	≤ 800 ml without cassette
Operating temperature range	4 - 40 (° C)
Pneumatic supply	6 - 8 barg
System dimensions	2.1 m W x 1.8 m D x 8 m H
Power requirements	Instrument power: 120 - 240 VAC, 1 ph, 50/60 Hz, main fuse 15A Main power: 120 - 240 VAC, 1 ph, 50/60 Hz, main fuse 15A
Flow measurement locations	Retentate, permeate
Flow measurement range	0 - 18 LPM
Flow measurement accuracy	0 - 1.8 LPM: ± 0.36 LPM, 1.8-18 LPM: ±2% of reading
Pressure measurement locations	Feed, retentate, permeate, addition
Pressure measurement range	0 - 4.14 barg
Pressure measurement accuracy	±0.3% of calibrated span
Air/Bubble sensor location	Addition
Conductivity measurement locations	Permeate (optional: retentate)
Conductivity measurement range	Low range: 0 µS/cm to 100 µS/cm (permeate) High range: 0.1 mS/cm to 150 mS/cm
Conductivity measurement accuracy	Low range: ± 2% of reading + 1% of full scale High range: ± 2% of reading + 1% of full scale
Temperature measurement location	Permeate
Temperature measurement range	2 - 50° C
Temperature measurement accuracy	±1° C



Specifications

System specifications	
Integrity test mass flow meter range	0.002 - 5 slpm
Integrity test mass flow meter accuracy	±0.6% of reading or ±0.1% of full scale, whichever is greater (ml/min)
UV measurement location	Permeate (Optional)
UV measurement range	0 - 1 AU
UV measurement accuracy	±1 % of reading +1% of full scale (including loop)
UV sensor wavelength	Optional: 254/280 nm or 280/300 nm
pH measurement location	Optional: permeate, retentate
pH measurement range	3 - 10 pH
pH measurement accuracy	±0.3pH (0 - 2 bar, 4 - 50° C)
Enclosure ratings	IP54 minimum
PLC	Allen Bradley CompactLogix
HMI	19" Touch screen and glass keyboard with Industrial PC mounted in control cabinet
Software platform	Wonderware System Platform
Operating system	Windows 10
Network connection	Ethernet/IP, RJ45
Network connectivity	External monitoring and control ready. Dedicated network connections for both the PLC and the HMI. Ready for connection to Active Directory domain for consolidated logons.
Compliance and regulatory	UL508A, EU Machinery Directive, 21 CFR Part 11, CE, RoHS, REACH and ALCOA+

Vessel specifications	
Maximum volume	50 L
Minimum volume with agitation	1.5 L with impeller covered
Minimum volume with recirculation	1.15 L with lowest inlet covered
Agitator range	0 - 150 rpm
Impeller type	Pitch blade (45° pitch)
Impeller blade count	3 per impeller
Impeller diameter	14.6 cm
Load cell range	0 - 300 kg
Load cell accuracy	±0.5% of full scale
Power requirements	120 - 230 VAC (+/- 10%), 1PH 50/60Hz main fuse 15A
Dimensions	0.70 m W x 0.75 m D x 1.45 m H

